

OPERATION and MAINTENANCE MANUAL

for

MODEL PV-15208

15 KW Grid-Tied
Photovoltaic Inverter

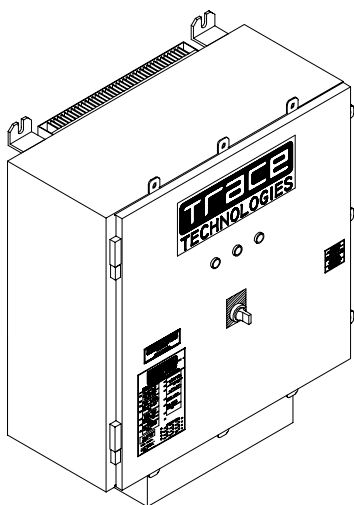

XANTREX
Smart Choice For Power

TRACE
TECHNOLOGIES

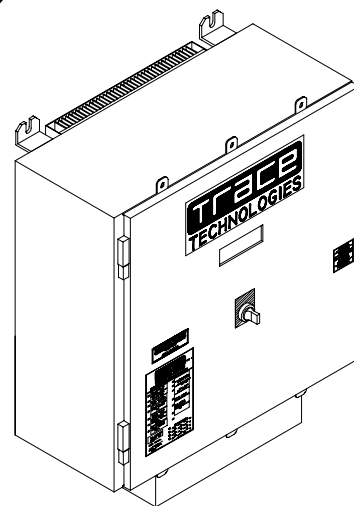

Document #150919
Revision B November 13, 2000

IMPORTANT SAFETY INSTRUCTIONS

SAVE THESE INSTRUCTIONS - THIS MANUAL CONTAINS IMPORTANT INSTRUCTIONS FOR TRACE TECHNOLOGIES MODEL PV-15208 GRID TIED PHOTOVOLTAIC INVERTER THAT SHALL BE FOLLOWED DURING INSTALLATION AND MAINTENANCE OF THE PV-15208.

Xantrex Technologies Inc./Trace Technologies Corp.
161-G SOUTH VASCO ROAD
Livermore, CA 94550
(925) 245-5400

Copyright 2000, Xantrex Technologies Inc./Trace Technologies Corp.

Table of Contents

Section 1: Product Description

- Introduction
- Major Components
- Interconnection Standards Compliance
- Specifications
- Equipment Symbol

Section 2: Safety

- Safety Features
- Isolation Procedure
- Anti Island Protection

Section 3: Installation And Initial Turn-On

- Isolation Transformer Requirements
- Torque and Wire Gauge Specifications
- Installation Instructions
- Interconnection Wiring
- Initial Turn On Procedure

Section 4: Operation

- Description of System Operation
- Operator Interface Panel (LED and LCD)
- Example of Normal System Operation

Section 5: Troubleshooting

- General
- Fault Conditions and Troubleshooting
- Fault Clearing
- Fault Descriptors and Troubleshooting

Section 6: Preventative Maintenance

- Isolation Procedure
- Turn-On Procedure

Section 7: Drawings and Major Parts Lists

- System Schematic, Grid Tied PV Inverter, PV-Series
- Assembly Drawings And Major Parts Lists
- Envelope Drawing, Grid Tied PV Inverter, PV-15208
- UL Listing Document, April 25, 2000
- UL Listing Card, September 8, 2000
- Accessories

INTRODUCTION

The Trace Technologies Model PV-15208 is a 15KW Grid Tied Photovoltaic Inverter. It utilizes advanced power electronics to allow interface of a photovoltaic array with a utility grid. The PV-15208 is a highly integrated assembly, consisting of an inverter bridge and associated control electronics all on a single board. The PV-15208 control software provides for complete overall system control with a variety of protective and safety features.

MAJOR COMPONENTS

The major components of the PV-15208 are identified in Drawing No. 150921.

Main Enclosure

The enclosure (shown in **Figure 1-1**) is NEMA-4 rated. The PV-15208 enclosure contains the Integrated Bus Board, output line filter (insuring that the PV-15208 line currents and voltages meet IEEE-519 harmonic distortion requirements), control power transformers, and A/C contactor (PV-15208 A/C output to the grid). Also found within the enclosure are the system protection devices (control power circuit fuses). The front door of the enclosure contains the operator interface panel (three LED's or LCD and an on/off switch).

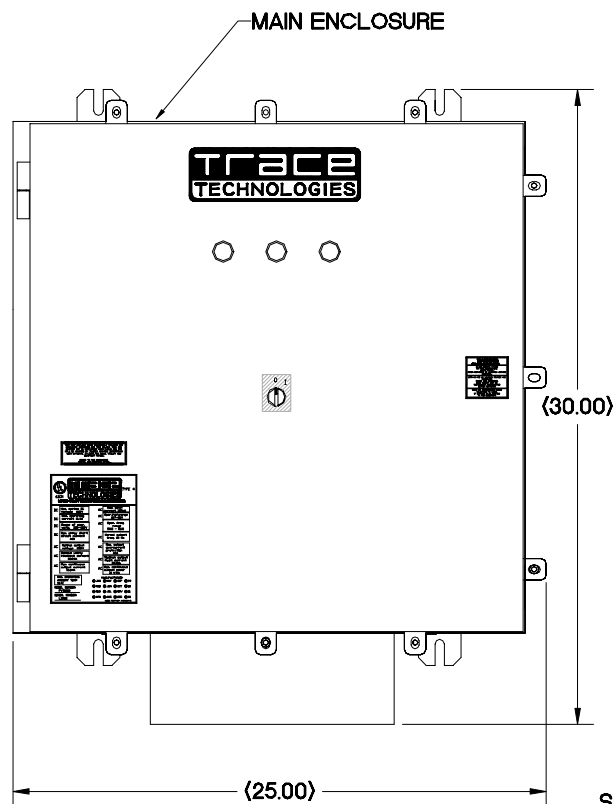

Figure 1-1

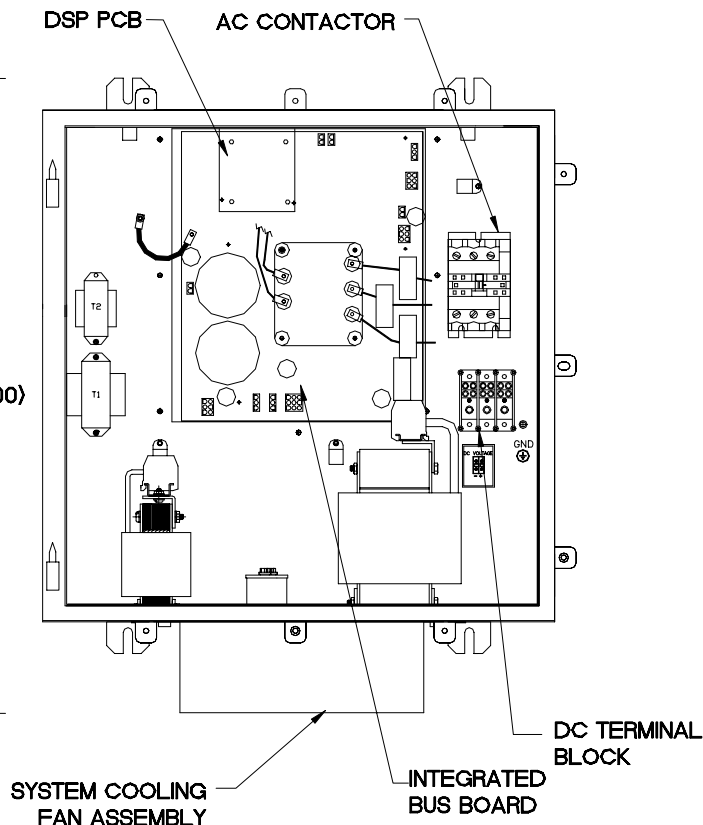

Figure 1-2

CAUTION

The fuses within the PV-15208 are intended for protecting the PV-15208 control circuitry only. They are not intended to provide protection for the PV array or external cabling.

Integrated Bus Board

The PV-15208 design makes use of a fully integrated bus board as shown in **Figure 1-2**. The bus board assembly is mounted to an aluminum extrusion heat sink, which mounts through an opening in the back of the enclosure. The power electronics is comprised of a six pack of IGBT devices, mounted to the heat sink. The bus board is mounted on top of the IGBT six pack device, and is supported through a series of standoffs attached to the heat sink.

The bus board contains all of the necessary control functions to drive the (attached) switching transistors. The bus board contains the following functional circuits: D/C control power supplies (+5V, +/-15V and four isolated +15V sources for the IGBT's), A/C and D/C high voltage measurement, A/C and ground current measurements, contactor and indicator controls, discrete input sensing (on/off switch), and closed loop PWM modulators. The bus board contains a micro-controller chip to perform the low-level control functions associated with the collection of measurement and driving the pulse width modulators.

A plug in DSP module controls the bus board. The DSP module is designed to the industry standard, PC-104 specification, and is used to perform the majority of the calculations needed to control the bus board. The most significant tasks are: control of PV-15208 electromechanical components and power electronics converters, signal conditioning (digital filtering and transformations), and communication with the operator interface panel and system sensors.

The PV array ties directly to the DC bus. The inverter controller manages the transfer of power between the DC bus and the utility grid.

INTERCONNECTION STANDARDS COMPLIANCE

The PV-15208 has been tested and certified by Underwriters Laboratories to be in compliance with **UL1741 Static Inverters And Charge Controllers For Use In Photovoltaic Power Systems**, as well as **IEEE-P929 Recommended Practice For Utility Interface Of Photovoltaic (PV) Systems**.

IEEE-P929 provides guidance regarding equipment and functions necessary to ensure compatible operation of photovoltaic systems which are connected in parallel with the electric utility. UL1741 is the test procedure performed by Underwriters Laboratory on the PV-15208 to verify it meets the recommendations of IEEE-P929. Refer to both documents for details of these recommendations and test procedures.

SPECIFICATIONS

The PV-15208 has been designed for photovoltaic power systems, which operate within the following specifications. Application of the PV-15208 in a manner inconsistent with these specifications may cause damage to the PV-15208 and other system components, and is a violation of the terms of the warranty.

Nominal AC Line Voltage	208 VAC, \pm 10%
Maximum AC Line Current	46.26 ARMS (at low line voltage)
Nominal Line Frequency	60 Hz, \pm 0.5 Hz
Continuous AC Load	15.0 KW @ 208 vAC
PV Voltage Range	330-600 VDC
PV Maximum Current	47.8 ADC
PV Configuration	Monopolar negative grounded, or bi-polar neutral ground
*Operating Temperature	-20 to 50° C
Storage Temperature	-40 to 50° C
Maximum Ambient Temperature Rating	50° C
Relative Humidity	To 95%, Non-condensing
Elevation	Derated above 6,600 feet
Dimensions (in inches)	30 X 25 X 14
Weight	Approx. 175 lbs.
Enclosure Type	NEMA 4
UL Listing File	File-E199356

*If ambient temperature is between -20 to 0° C, the unit must be powered up in standby for at least one hour prior to going on-line.

EQUIPMENT SYMBOL

Chassis ground – Customer supplied system ground connection point. This symbol may be found near a stud within the main enclosure. It is provided as a location to bond the electrical system equipment ground.



SAFETY FEATURES

WARNING

The PV-15208 enclosure contains exposed high voltage conductors. The enclosure door should remain closed, except during maintenance or testing. These servicing instructions are for use by qualified personnel only. To reduce the risk of electric shock, do not perform any servicing other than that specified in the operating instructions unless you are qualified to do so. Do not open the cabinet door if extreme moisture is present (rain or heavy dew).

Front Panel Indicators

The PV-15208 incorporates three colored LED indicators, used to show the current operating state of the inverter. The indicators have the following meanings:

- **Red:** Fault Mode - The inverter has sensed an abnormal condition. To reset the unit (clearing the fault condition), cycle the on/off switch (see below).
- **Amber:** Sleep Mode – The inverter is waiting for sufficient PV voltage to start the inverter.
- **Green:** Operator Mode - The inverter is active and generating A/C current.

On/Off Switch

The PV-15208 incorporates a maintained position on/off switch located on the front door of the enclosure. Under normal conditions, the on/off switch is in the on position. Turning the switch to the off position will initiate a controlled shutdown of the PV-15208 and open the main contactor within the unit. The PV-15208 is prevented from being restarted until the on/off switch is turned back to the on position. Cycling the on/off switch will reset the PV-15208 and attempt to clear any system fault.

Main Enclosure Door

The front door of the PV-15208 main enclosure is pad lockable. It is recommended that the PV-15208 enclosure door be padlocked during normal operation.

WARNING

The PV-15208 does not incorporate a door interlock switch. Please make sure the unit is powered down, and isolated from the utility grid and PV panels, prior to opening the enclosure door. (Allow 5 minutes for any stored potentials to be discharged, prior to opening the unit). The front door of the PV-15208 main enclosure is pad lockable. It is recommended that the PV-15208 enclosure door be padlocked during normal operation.

Fault Reporting

Any fault conditions are reported to the operator interface. If the PV-15208 is equipped with LED's, the red LED will light and the green LED will flash the corresponding number of the fault. If the PV-15208 is equipped with the LCD option, the LCD will display a text description of the fault. Refer to Section 5, Troubleshooting, for detailed descriptions of system fault conditions.

PV Ground Fault Detection

The PV-15208 is equipped with ground fault detection circuitry and control. The single point of PV

system ground must be routed through CT1 on the main control board (see section 3, installation and section 7, system schematic for further detail). Upon detection of 1.5 amps of ground fault current, the PV-15208 executes an orderly shutdown, and annunciates a ground fault at the operator interface. The PV-15208 will remain faulted until the ground fault is remedied and cleared at the operator interface (see section 5, troubleshooting).

ISOLATION PROCEDURE

The following procedure should be followed to de-energize the PV-15208 for maintenance:

WARNING

The terminals of the PV input may be energized if the arrays are energized. In addition, allow 5 minutes for all capacitors within the enclosure to discharge after disconnecting the PV-15208 from AC and DC sources.

1. Turn the on/off switch to the off position.
2. Open the PV array disconnect switch (if present).
3. Open the AC interface disconnect (if present).
4. Open the isolation transformer circuit breaker.
5. Install lockout devices on the isolation transformer circuit breaker and PV disconnect switch (if present).

ANTI ISLAND PROTECTION

A digital phase-shift-loop (PSL) circuit is implemented in the DSP inverter controller to prevent “Islanding” of the PV-15208.

The DSP continuously makes minor adjustments to the power factor phase angle above and below unity. In the event of a utility outage, these adjustments destabilize the feedback between the inverter and the remaining load, resulting in an over/under frequency or voltage condition. The PV-15208 then performs an orderly shutdown. The fault condition will remain until the utility voltage and frequency have returned to normal for 5 minutes.

This method has been extensively tested and proven to exceed the requirements of UL 1741.

ISOLATION TRANSFORMER REQUIREMENTS

The PV-15208 is required to have an isolation transformer wired between the inverter AC output and the utility interconnection. Any standard dry-type isolation transformer is compatible with the PV-15208 as long as the inverter side is rated for a minimum of 15KVA continuous duty.

WARNING

Check with the local utility of jurisdiction when selecting the winding configuration of the isolation transformer. Individual utilities may have unique requirements related to isolation transformer wiring. Some winding configurations may keep the PV-15208 from detecting a loss of phase condition on the utility system which may allow potentially lethal voltage to be present on the open phase wirings.

Inverter Side Isolation Transformer Requirements

The inverter side transformer windings may be configured either delta or WYE, and must be rated for 208 VAC. Trace Technologies recommends using a delta wound transformer to avoid installation mistakes. **If a WYE wound transformer is used to interface with the PV-15208, and the PV array is grounded, the neutral (X0) must be left floating.** If the neutral is tied to ground, the inverter will not function properly, and may be damaged.

Utility Side Isolation Transformer Requirements

The utility side isolation transformer windings may be configured either delta or WYE, and must be rated for the utility voltage at the point of utility inter-connection. Check with the utility of jurisdiction when selecting an isolation transformer configuration. If a WYE wound transformer is used to interface with the utility, it is not necessary to connect the neutral (X0) to ground. The PV-15208 is a balanced, three phase, current sourcing inverter, and only operates with the presence of a stable utility voltage. Single phase grounded loads which may be present between the transformer and utility, will maintain their existing ground reference at the utility distribution transformer. Grounding the neutral of a WYE wound transformer may create an “open delta” condition, depending on the utility configuration. **This condition may keep the PV-15208 from detecting a loss of phase condition on the utility system, which may allow potentially lethal voltage to be present on the open phase wiring.**

Contact your Xantrex/Trace Technologies distributor if you have any questions regarding isolation transformer requirements.

TORQUE AND WIRE GAUGE SPECIFICATIONS

The following torque specifications are to be used on all electrical interfaces made during installation of the PV-15208.

Torque Table	
Terminal Block or Bolt Size	Torque Setting
M6-1	52 in lbs./5.9 Nm
Ferraz/Shawmut 62132	20-120 in lbs/2.3-13.6 Nm

The following table shows acceptable wire gauges to be connected to the PV-15208 AC and DC inputs.

Wire Gauge Table	
Termination	Wire Range AWG
Contactor (AC)	#3-#10
Distribution Block (DC)	2/0-#14

INSTALLATION INSTRUCTIONS

CAUTION

All wiring methods shall be in accordance with the National Electrical Code ANSI/NFPA 70. All power conductors interfacing to the PV-15208 should be sized in accordance with the National Electric Code ANSI/NFPA 70 and local codes. Large gauge wire must have a minimum bend radius dependent upon the wire gauge (refer to the National Electric Code, Article 373-6B). Take care to keep the wire bundles away from any sharp edges which may damage wire insulation over time. Trace Technologies recommends using No. 6 AWG, 105 degrees C, minimum, copper wire for all connections with the PV-15208.

Ventilation Considerations

1. Maintain a minimum 6” clearance above and below the PV-15208 for proper cooling fan operation.
2. Maintain a minimum 1” clearance to the left and right of the PV-15208.

Installation

1. The unit must be mounted at least 3’ off the ground, and 12” above any horizontal surface.
2. Screw two 3/8” x 3-1/2” long lag bolts into existing studs in the wall (16-inch mounting center) at lower mounting level on PV-15208. Lag bolts should be horizontally level with each other. Leave a minimum of 1” of bolt protruding from the wall.
3. Place the PV-15208 bottom mounting ears, shown in **Figure 3-1** and **Figure 3-2** onto installed lag bolts. (See following page.)
4. Hold the unit against wall and install upper lag bolts (3/8” x 3-1/2”). Tighten bolts firmly.
5. Tighten lower lag bolts while unit is held in place.
6. Install two 1-1/2” liquid tight connectors (included with the PV-15208) where shown in **Figure 3-3**. (See following page.)

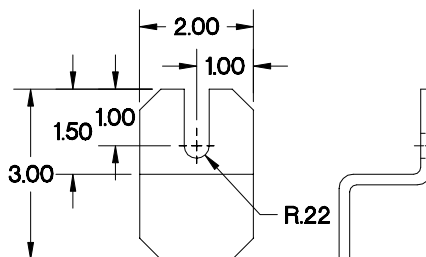

Figure 3-1

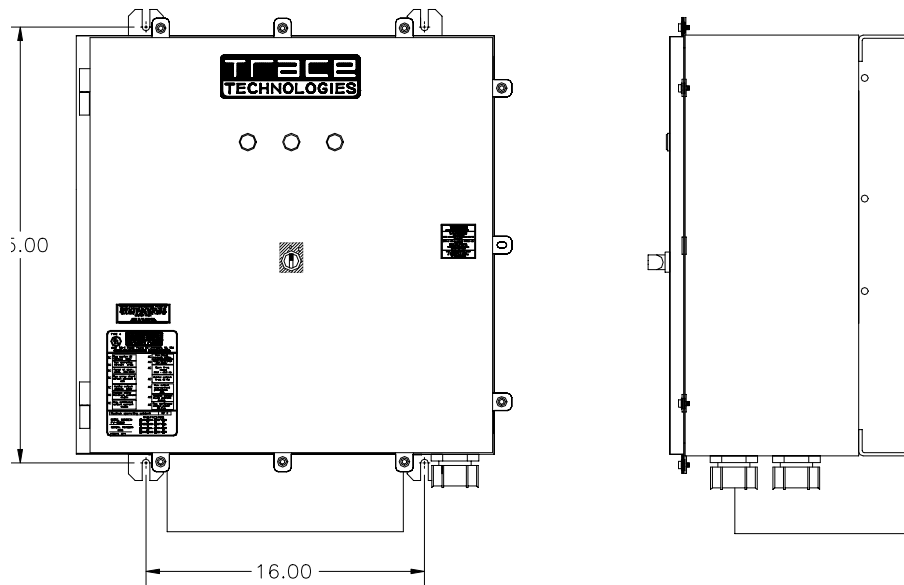

Figure 3-2

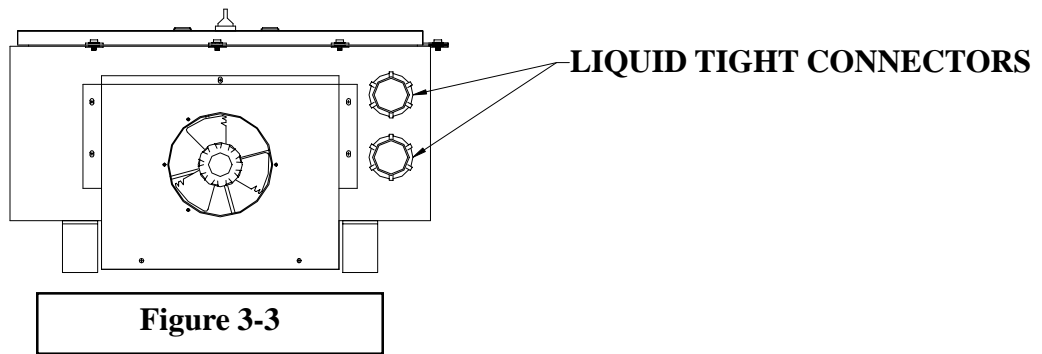
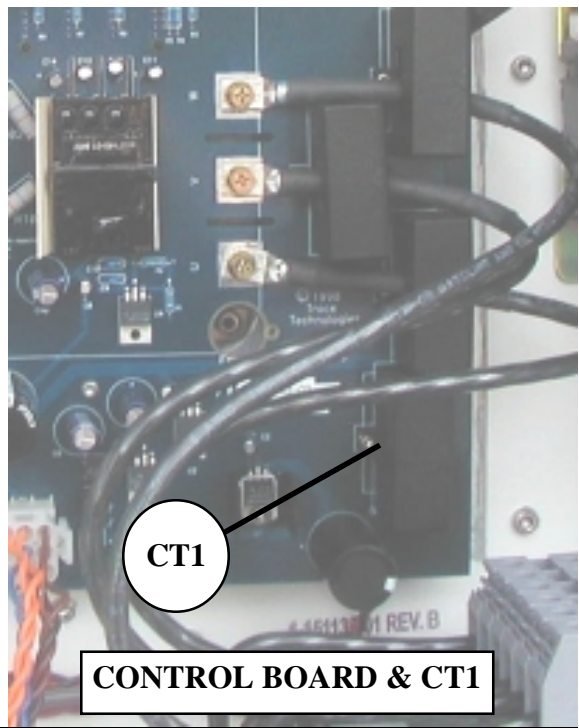

Figure 3-3

Array Grounding and Ground Fault Detection
 If grounding the PV array is required for monopolar or bipolar arrays, jumper TB1-2 to a (PV-) cabinet ground stud. If ground fault detection is required, route this jumper through CT1 located on the lower right hand corner of the control board (see the system schematic for further detail). This must be the only point of PV grounding for the PV-15208 and the ground fault detection system to function properly.

CAUTION

The input and output circuits are isolated from the enclosure, and that system grounding, if required by sections 690-41 and 690-42 of the National Electric Code, ANSI/NFPA 70, is the responsibility of the installer.



CONTROL BOARD & CT1

Phase-Sequencing

The PV-15208 is equipped with an automatic phase-detection control algorithm. This allows the utility interface conductors to be connected in any sequence convenient at the time of installation. Upon system initialization at power-up, the PV-15208 determines the phase sequence of the utility connection and configures the modulator drivers accordingly.

INTERCONNECTION WIRING

CAUTION

To reduce the risk of fire, connect only to a circuit provided with 65 amperes maximum branch circuit overcurrent protection in accordance with the National Electrical Code, ANSI/NFPA 70.

The following wires for connecting the PV-15208 to external devices are not provided by Xantrex/Trace Technologies: (See wiring diagram on the following page.)

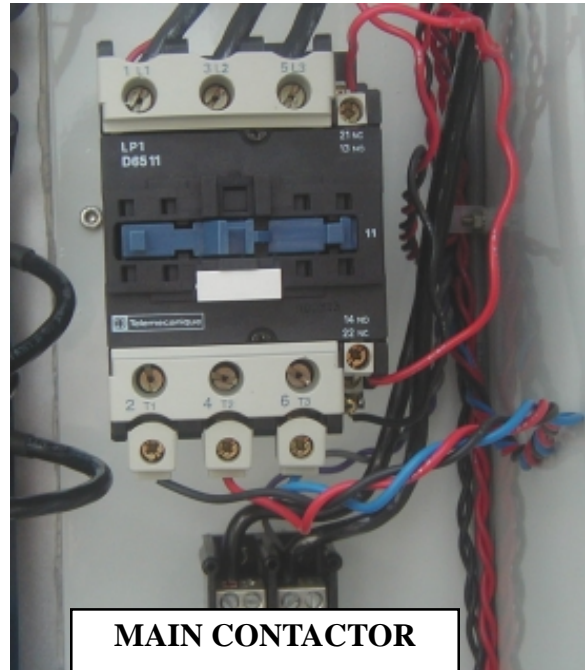

- 3-Phase 208 VAC inverter output (main contactor, see picture) to terminals of the 208 VAC delta side of isolation transformer. **If the inverter side of the isolation transformer is configured WYE and the PV array is grounded, the neutral must be left floating. Ground loops will exist when the inverter starts switching, which will cause the inverter to shut down due to phase over-currents and may result in damage to the PV-15208. Also, insure that this neutral is not bonded to the isolation transformer frame.**
- System ground to the isolation transformer chassis ground.
- Isolation transformer grid side terminals to line circuit breaker (or the AC disconnect switch if present).
- PV frame ground to PV-15208 enclosure chassis ground stud.
- PV-15208 enclosure chassis ground stud to the electrical distribution system ground.
- PV+ to the inverter enclosure terminal block TB1-1.
- PV- to the inverter enclosure terminal block TB1-2.

Install all wires listed above. Refer to the system schematics in Section 7 for more detailed terminal locations.

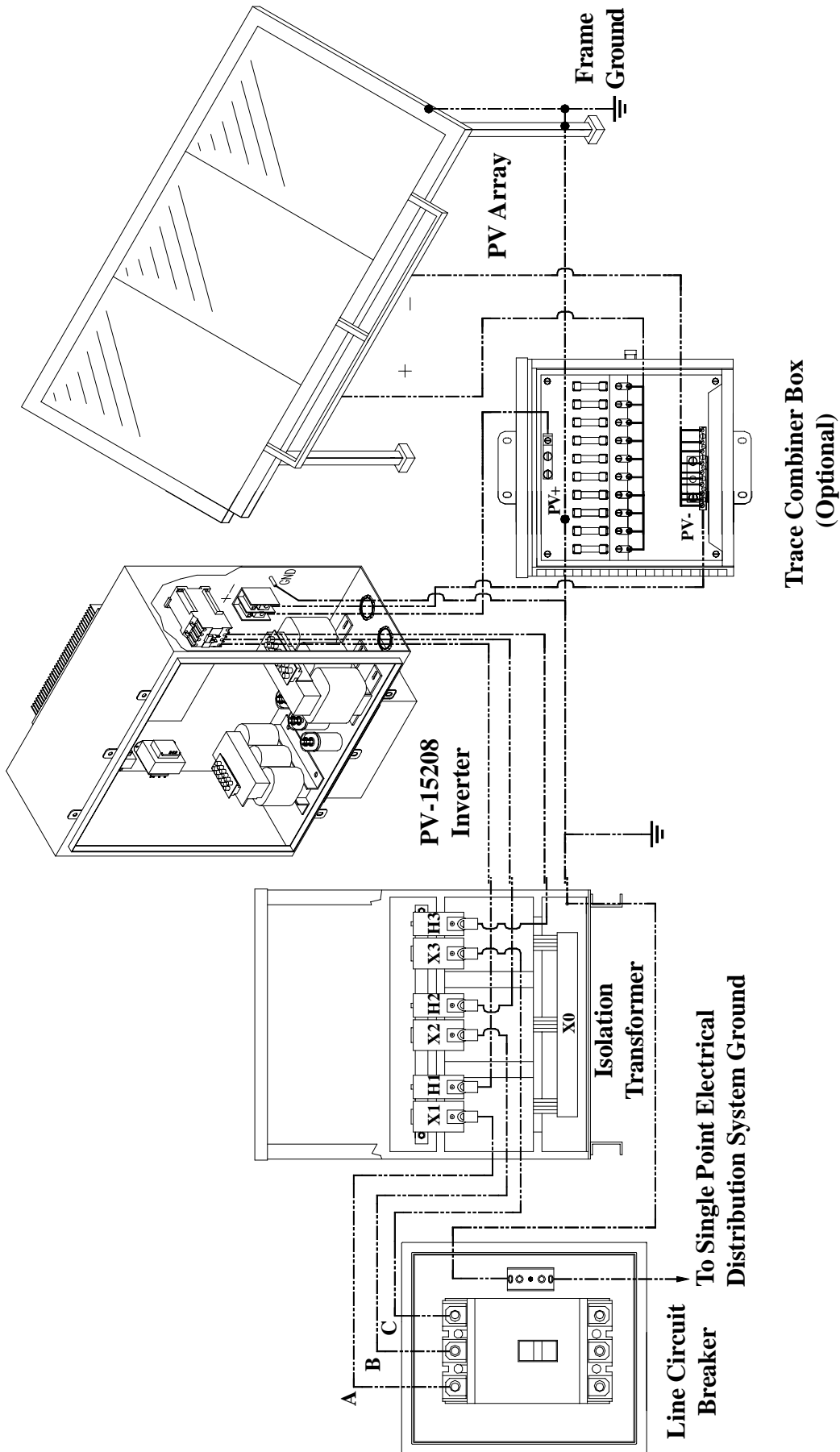

Wiring Diagram

INITIAL TURN ON PROCEDURE

The following procedures are intended to verify correct installation and proper operation of the PV-15208. These steps are to be followed sequentially. Do not continue if any of the steps or results are unclear. Refer to Section 4 for a detailed description of system operation. Refer to Section 5 for fault condition descriptions and troubleshooting. Refer to Section 7 for detailed system schematics.

Visual Inspection, Isolation Transformer

- Verify the isolation transformer circuit breaker is open.
- Remove the isolation transformer access panel.
- If the inverter side of the isolation transformer is configured WYE, the neutral must be left floating. The transformer neutral must not be connected to the utility side neutral, the transformer chassis, or ground.
- Verify the inverter 208 VAC conductors are connected to the isolation transformer.
- Verify the utility conductors are properly connected to the isolation transformer.

Visual Inspection, PV-15208

- Insure AC and DC disconnect are opened (if present).
- Insure PV array string disconnect switches are opened (if present).
- Open the door of the enclosure, and inspect.
- Verify all wire connections are tight.
- Inspect the cables between the terminal blocks and the matrix driver board. All wire harnesses should be snap-locked into their respective PCB headers.

Visual Inspection, PV Array Wiring

- Verify the PV+, PV-, PV neutral (if array is bipolar), and PV safety ground are isolated from each other. The PV safety ground should be bonded to the enclosure ground stud. Refer to system schematic in Section 7.
- Verify all PV fuses are installed (if present).
- Verify PV string diodes are wired properly (if present).
- Verify proper PV voltage polarity at the PV string disconnect/combiner boxes.

Initial Power

- Close the isolation transformer circuit breaker.
- Verify 208 VAC voltage across the AC disconnect.
- Close the AC disconnect (if present).
- With the DC disconnect switch opened (if present), close one of the PV array string disconnect devices.
- Carefully measure VDC at the PV disconnect switch. The value should be the same as at the PV array string disconnect device. It should also be positive.
- Close the PV disconnect switch (if present).
- Carefully measure VDC across TB1-1 and TB1-2 (PV +/-) terminal block. The value should be the same as at the PV



array string disconnect device. It should also be positive.

- Carefully measure VDC across the matrix + and – busses. The value should be the same as at the PV array string disconnect switch. It should also be positive.
- Open the PV disconnect switch. The matrix capacitor bank voltage should slowly degrade to near zero over a 5-minute period.
- Open all PV string disconnect switches.

System Verification

- Ensure the on/off switch is enabled.
- Upon applying 208 VAC power to the PV-15208, observe the three LED indicator lights on the front door. The LED's should be switching on and off in a sequenced pattern. The LED's may be difficult to see depending on external light conditions. After approximately 15 seconds, the panel should finish initialization
- Remedy any faults reported. If the fault indicator does not change, the fault condition is still present (see Section 5). Cycling the on/off switch will reset the PV-15208 and attempt to clear any system faults. Once all faults are cleared, the amber indicator light will come on indicating the PV-15208 is in standby.
- Close all PV array string disconnect switches (if present).
- Close the main PV disconnect switch (if present).
- If the PV voltage is above the PV Start Voltage setpoint, and the PV Start Time is exceeded, the PV-15208 should transition to “Power Tracking” (see Section 4, Operation).
- Depending upon solar conditions, the PV-15208 may not operate at full power. If the PV array is not experiencing full sun, the PV maximum power tracker will regulate the PV voltage to maintain maximum PV power output. (See section 4 for further description of the peak power tracker).
- The PV-15208 is now fully operational.

Fine Tuning

- All PV-15208 operating parameters have been set at the factory, based upon prior experience with various PV arrays. Parameters may be modified using an optional graphical user interface. Contact your Xantrex/Trace Technologies distributor for further information.
- It is recommended that the PV-15208 be watched during Wake-Up and Sleep Test. If the PV-15208 cycles between operating and sleeping at either of these times, the operating setpoints may not be set properly. (Refer to Section 4 for a detailed description of PV-15208 operating states). The PV-15208 should not cycle if the setpoints are set properly.

DESCRIPTION OF SYSTEM OPERATION

Overview

The PV-15208 is a fully automated grid-tied photovoltaic inverter. Manual interaction or control of the inverter is necessary only in the event of a system fault. The following conditions govern PV-15208 operation:

- Stable utility voltage and frequency must be present for all states of operation.
- Fault states are automatic from any state of operation. A fault will cause the PV-15208 to immediately stop processing all power. The fault condition will be reported to the operator interface.
- The on/off switch, located on the front door of the PV-15208, must be switched to the on position for all operating states.
- Cycling the on/off switch attempts to clear any system faults and return the PV-15208 to normal operation.

Operating States

Control software governs the operation of the PV-15208. There are five main operating states. The following descriptions depict the LED interface. Inverters configured with LCD displays will indicate operating states on the display.

- **Standby:** The amber LED is illuminated. The PCU monitors the status of the PV array and utility grid, waiting until the PV array voltage is sufficient to export power to the utility.
- **Wake-Up:** The amber LED is illuminated. Once the PV voltage is sufficient to export power to the utility grid, the PV-15208 will wait 5 minutes before starting to insure the voltage is not transient in nature. This keeps the system from cycling during unstable irradiance conditions.
- **Power Tracking:** The green LED will illuminate while the PV-15208 delivers power to the utility. This is the standard operating state of the PV-15208. The PV-15208 maximum power tracker will optimize power output from the PV array. If available PV power is above the maximum power rating of the PV-15208, the inverter will current limit, which will cause the PV voltage to rise above the array peak power voltage. The minimum operating voltage of the PV-15208 is 330 VDC. The power tracker will not track voltage below this point, regardless of the actual peak power voltage of the PV array.
- **Sleep Test:** The control system will begin a 5 minute sleep test. This normally indicates the PV irradiance is declining as the sun sets. If the output power remains below 200 watts during the 5 minute sleep test, the system will transition to standby. The time delay allows the inverter to ride through any temporary irradiance reductions.
- **Fault:** The PV-15208 has encountered a fault condition. When this happens, regardless of the PV-15208 state-of-operation, the PV-15208 will stop processing all power and execute an orderly system shutdown. The red LED will illuminate while the yellow and green LED's flash the fault code (See section 5, Troubleshooting).

OPERATOR INTERFACE (LED and LCD)

NOTE

On early versions of the PV-15208, a push-pull Emergency Stop switch was used instead of the on/off switch. It functioned in the same manner described for the on/off switch.

The standard operator interface on the PV-15208 consists of 3 system status indicator LED's and an on/off switch. The LED's indicate the following states of operation:

- **Red LED:** Indicates the system is faulted or the on/off switch is switched to the off position. The inverter will not function while this LED is illuminated. Cycling the on/off switch will attempt to clear the fault condition and allow the inverter to resume normal operation.
- **Amber LED:** Indicates the inverter is in standby, waiting for sufficient DC voltage to begin peak power tracking. This LED will turn off once the PV-15208 begins producing power. In the event of a fault condition, the amber LED will flash, indicating the beginning of the fault code sequence (See section 5, Troubleshooting).
- **Green LED:** Indicates the inverter is on-line and outputting power. In the event of a fault, the green LED will flash a sequence indicating the fault code (See section 5, Troubleshooting).

The on/off switch is used to enable or disable system operation. The on/off switch is also used to reset the inverter and clear any system faults.

The PV-15208 may be equipped with an optional Liquid Crystal Display instead of the LED indicators. The display consists of 4 text lines containing the following information:

- **Line 1: System Goal State** - This is the target state of the inverter.
- **Line 2: System Status** - The current operating state of the inverter.
- **Line 3: Inverter Output Power or Fault Description** - During normal operation, this line will report the inverter real time output power. If the PV-15208 is faulted, this line will report a description of the fault condition.
- **Line 4: PV Voltage** - The DC voltage measured at the PV-15208 DC input terminals.

The following is a typical display of the LCD during the five operating states and an on/off switch.

Status: Power Track
Shutdown

Standby

Status: Power Track
Wake Up Test

Wake Up

Status: Power Track
Power Tracking
Line kVA:
PV Volts:

Power Tracking

Status: Power Track
Sleep Test

Sleep Test

Status: Power Track
Faulted
Fault Description

Fault

Status: Power Track
Emergency Stop

Emergency Stop

EXAMPLE OF NORMAL SYSTEM OPERATION

Upon initial application of AC voltage, the LED's located on the front door will sequentially flash for approximately 15 seconds. Once the system has finished initializing, the PV-15208 will remain in standby until adequate PV voltage is available (amber LED is lit). 5 minutes after the PV start voltage has been reached, the PV-15208 will synchronize to the utility grid and begin peak power tracking the PV array. The time delay protects the inverter from excessive on/off cycling.

The PV-15208 will continue to process power until the AC output power approaches the operating losses of the inverter for a period of 5 minutes. The time delay protects the inverter from excessive on/off cycling.

SYSTEM OPERATING PARAMETERS

The PV-15208 contains a number of system operating parameters which may be field adjusted using an optional graphical user interface program available first quarter, 2001 (contact Xantrex/Trace Technologies for further information). All operating parameters have been set at the factory during system test based upon prior experience with various PV arrays, or to be in compliance with UL1741. In general, the factory default settings allow for stable and efficient operation of the PV-15208 connected with any PV array configured for a 330-500 VDC peak power voltage point.

Below is a list of the PV-15208 operating parameters, showing valid ranges and the factory default settings. Some field adjustable parameters are password protected and may only be changed by trained service technicians. In particular are parameters relating to utility protection setpoints. These have been set in the factory to the limits mandated by UL1741. Any changes to these setpoints should be agreed upon by the local utility and the equipment owner. The ability to adjust the voltage and frequency setpoints across the actual utility voltage and frequency has been provided as a simulation tool to verify the PV-15208 accurately detects and responds to a utility excursion. This test should only be performed by a trained service technician. It is possible to adjust the setpoints in a manner that will prevent the PV-15208 from functioning.

Parameter	Description	User Settable Range	Resolution	Factory Default Setting	Password Protected
PV_V_Start	PV Wake Up Voltage	332-600	0.1 V	380	
PV_Stop_Watts	PV Shut Down Output Power	100-1000	0.1 W	200	
PPT_Max_I_Per	Commanded Output Power As A Percent Of Rated Power	0-100	1 A	100	*
PPT_V_Ref	Starting PV Voltage For Peak Power Tracker	332-600	0.1 V	350	

-continued-

Parameter	Description	User Settable Range	Resolution	Factory Default Setting	Password Protected
PPT_V_Step	Peak Power Tracker Perturbation Step Voltage	0.0-10.0	0.1 V	1.5	
Ground_I_Max	Maximum Allowable Ground Fault Current	1.0-10.0	0.1 A	3.0	
Serial Number	Inverter Serial Number	0000-9999	N/A	Factory Set	*
Freq_Max	Maximum Allowable Utility Frequency	57.0-63.0	0.1 Hz	60.5	*
Freq_Min	Minimum Allowable Utility Frequency	57.0-63.0	0.1 Hz	59.5	*
Freq_Max_Delay	Maximum Allowable Time Response To A Utility High Frequency Excursion	0-60	1 Cycle	3	*
Freq_Min_Delay	Maximum Allowable Time Response To A Utility Low Frequency Excursion	0-60	1 Cycle	3	*
VAC_Max	Maximum Allowable Utility Voltage	166.4-249.6	0.1 V	220.5	*
VAC_Min	Minimum Allowable Utility Voltage	166.4-249.6	0.1 V	195.5	*
VAC_Max_Delay	Maximum Allowable Time Response To A Utility High Voltage Excursion	0-60	1 Cycle	5	*
VAC_Min_Delay	Maximum Allowable Time Response To A Utility Low Voltage Excursion	0-60	1 Cycle	5	*

GENERAL

In the event of a fault, the PV-15208 will annunciate the condition at the operator interface. The PV-15208 will execute an orderly shutdown and remain faulted until the fault is cleared (manually or automatically).

In general, the operator should respond to any PV-15208 fault as follows:

1. The source of the fault should be sought by referring to the following chart.
2. Rectify the fault condition and attempt to clear the fault by cycling the on/off switch.
3. If the problem cannot be corrected, contact your Xantrex/Trace Technologies distributor for assistance or service.

FAULT CONDITIONS AND TROUBLESHOOTING

Fault Code Annunciation

The PV-15208 will report faults by LED display blinking the amber and green LED's on the front door of the inverter. If a fault is detected, the red LED will light continuously and the amber and green LED's will blink the sequence of the fault. The amber LED will light once, indicating the beginning of the fault code sequence (first count). The green LED will blink X number of times, indicating the remainder of the fault count. For example: If the PV-15208 experiences a ground fault (fault #3), the yellow and green LED will flash once then the green LED will flash twice again. This sequence will repeat until the fault condition has been corrected and cleared.

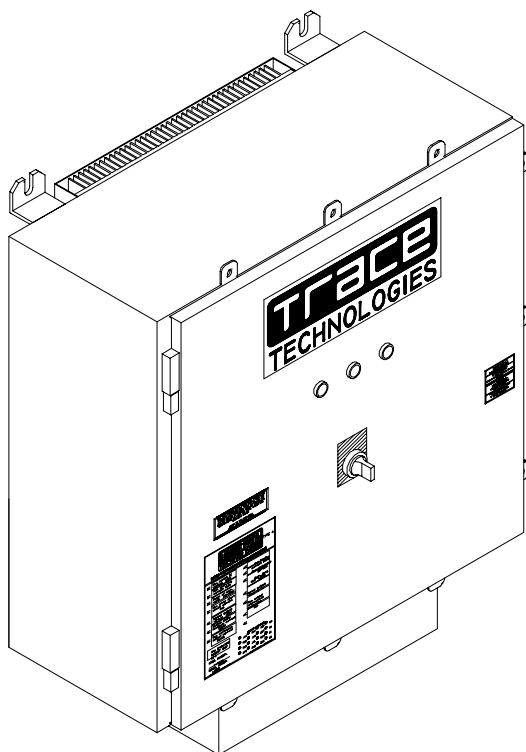

LED Display

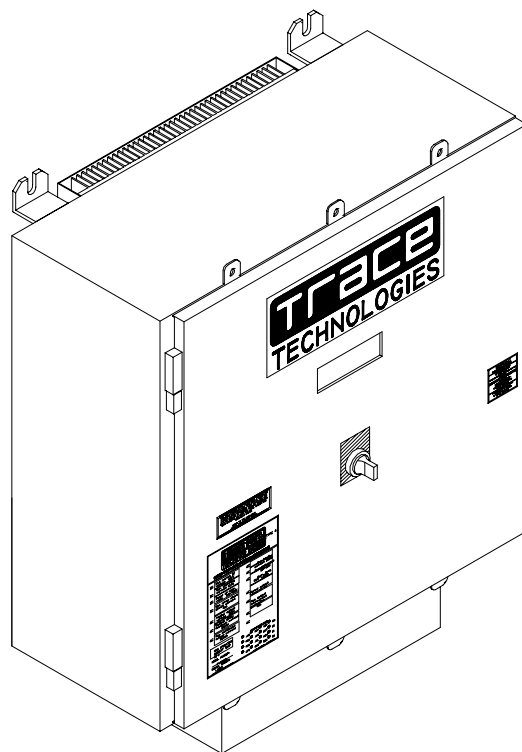

LCD Display

LCD Fault Annunciation (Optional Equipment)

The LCD interface reports fault conditions on Line 2 and 3. The fault code number will follow a text description. The fault description will remain displayed until the fault has been corrected and cleared. Each fault is described below.

FAULT DESCRIPTIONS

Fault Description	Number of LED Flashes	Fault Code (LCD)
IPM Over Current	1	0x0002
IPM Over Temperature	2	0x0001
Ground Current	3	0x0080
SW DC/PV Over Voltage	4	0x0040
AC Line Under Frequency	5	0x0400
AC Line Over Frequency	6	0x0800
AC Line Voltage Low	7	0x0100
AC Line Voltage High	8	0x0200
DC Bus Over Voltage	9	0x0020
Internal System Fault	10	0x0010
Emergency Stop	None	None

FAULT CLEARING

Once the cause of the fault condition has been corrected, the fault can be cleared with the on/off switch. First turn the switch to the off position and then back to the on position in order to reset the inverter. If a fault is sustained the inverter will not reset, and will continue to report the fault. Once the fault clears, the red LED will turn off and the yellow LED will remain lit.

FAULT DESCRIPTIONS AND TROUBLESHOOTING

(1) IPM Over Current Fault (0x0002)

The IPM module has detected a short circuit/over current condition, or low supply voltage.

Possible causes:

- Short circuit in output AC line.
- Low supply voltage to IPM control circuit.
- Shorted isolation transformer.

(2) IPM Over Temp Fault (0x0001)

The IPM module has exceeded its maximum allowable temperature.

Possible causes:

- Clogged inlet filter.
- External cooling fan inoperable.
- Airflow on heat sink impeded due to accumulation of debris.
- Operation above rated ambient temperature for an extended period of time.
- Auxiliary contact block on contactor K1 inoperable. This is only possible if the fan does not operate when the contactor closes. Carefully check voltage at the K1-N.O. aux. contact to the ground bus when the contactor is closed. (See schematic in Section 7)

(3) Ground Current Fault (0x0080)

The earth safety ground current has exceeded the maximum-programmed value.

Possible causes:

- The negative wire from the PV array has been passed through CT1. Remove wire and connect to TB1-2. Run wire from TB1-2, through CT1, and land at one of the chassis ground studs.
- Inspect the PV array for actual ground faults.
- The PV array has been grounded in more than one location. If the PV array is grounded through CT1, it must not be grounded at any other location.
- CT1 defective: Contact your Xantrex/Trace Technologies distributor for assistance or service.

(4) SW PV/DC Over Voltage Fault (0x0040)

The PV voltage has exceeded the maximum programmed limit. This limit is set to 600 VDC during system test.

Check the PV input voltage at the PV disconnect switch. If the voltage is below 600 VDC, restart the PV-15208.

Possible causes:

- The PV array open circuit voltage exceeded 600 VDC.
- There is a problem with the PV voltage sense wiring (see system schematic in Section 7).

(5) AC Line Under Frequency Fault (0x0400)

The AC utility frequency fell below the minimum programmed limit. This limit is set to 59.5 Hz and the system response time limit is set to 3 cycles to insure the PV-15208 disconnects from the utility within the time limit allowed by UL1741.

Possible causes:

- The utility frequency fell below the allowable limit (59.5 Hz by default). Verify the utility frequency is stable and within allowable operating limits.
- There is a problem with one or more of the AC sense wires (see system schematic in Section 7).

This fault is auto-resetting. The unit will automatically restart after line has stabilized within normal limits for 5 minutes.

(6) AC Line Over Frequency Fault (0x0800)

The AC frequency exceeded the maximum-programmed limit. This limit is set to 60.5 Hz and the system response time limit is set to 3 cycles to insure the PV-15208 disconnects from the utility within the time allowed by UL1741.

Possible causes:

- The utility frequency exceeded the allowable limit (60.5 Hz by default). Verify the utility frequency is stable and within allowable operating limits.
- There is a problem with one or more of the AC sense wires (see system schematic in Section 7).

This fault is auto-resetting. The unit will automatically restart after line has stabilized within normal limits for 5 minutes.

(7) AC Line Voltage Low Fault (0x0100)

The utility AC voltage fell below the minimum programmed limit. There are two levels of response to low line voltage conditions. The first level of response is set to 195.5 VAC with a time delay of 5 cycles. By default, the second level is set to 156 VAC with a time delay of 1 cycle, and is not field adjustable.

Possible causes:

- The utility voltage fell below the allowable limit (195.5 VAC by default). Verify the utility voltage is stable and within allowable operating limits.
- There is a problem with one or more of the AC sense wires (see system schematic in Section 7).

This fault is auto-resetting. The unit will automatically restart after line has stabilized within normal limits for 5 minutes.

(8) AC Line Voltage High Fault (0x0200)

The utility AC voltage exceeded the maximum-programmed limit. There are two levels of response to high line voltage conditions. The first level of response is set to 220.5 VAC with a time delay of 5 cycles. By default, the second level is set to 247.5 VAC with a time delay of 1 cycle, and is not field adjustable.

Possible causes:

- The utility voltage exceeded the allowable limit (220.5 VAC by default). Verify the utility voltage is stable and within allowable operating limits.
- There is a problem with one or more of the AC sense wires (see system schematic in Section 7).

The fault is auto-resetting. The unit will automatically restart after line has stabilized within normal limits for 5 minutes.

(9) DC Bus Over Voltage Fault - Hardware (0x0020)

The DC bus voltage has exceeded the maximum limit.

This is also the PV input voltage sense point. Check the PV input voltage at the PV disconnect switch. If the voltage is below 600 VDC, cycle the on/off switch and restart the PV-15208.

Possible causes:

- The PV array open circuit voltage exceeded 600 VDC.
- There is a problem with the PV voltage sense wiring (see system schematic in Section 7).

(10) Internal System Fault

There has been an internal system fault. Contact your Xantrex/Trace Technologies distributor.

Possible cause:

- There is a problem with the integrated bus board or DSP control board.

Emergency Stop Fault

The on/off switch, located on the front door of the enclosure is disabled. The contact block on the back of the switch must be open for the PV-15208 to report this message.

If the switch is enabled and the red indicator light is still on, isolate the PV-15208 from external power, then:

- Verify continuity across the switch contact block while the switch is turned to the on position.
- Verify continuity between P7-1 and P7-2 while the switch is enabled.

This message will display on the second line of the LCD display. It does not indicate a system fault if the on/off switch is turned to the off position.

Xantrex/Trace Technologies recommends that the following preventative maintenance be carried out on the PV-15208:

Monthly intervals or as required:

Aluminum Extrusion Heatsink

Accumulation of dirt and debris on the aluminum extrusion heatsink and fan shroud will decrease the ability to transfer heat, which can cause the PV-15208 to shutdown on over-temperature alarms. Inspect the aluminum extrusion heatsink and fan shroud for accumulation of dirt. Clean if debris is present.

Fan Operation

Verify proper operation of the heatsink cooling fan, located within the shroud below the enclosure. The fan operates when the K1 contactor is closed. Remove any debris from the fan and finger guard.

Six month intervals:

Enclosure Seals

Inspect the enclosure door seal. If damaged, replace with equivalent closed cell foam gasket. Call your Xantrex/Trace Technologies distributor for factory replacements or specifications.

Electrical Connections

Inspect the condition of all cables interfacing to the PV-15208. Inspect all wire crimps and connections for damage caused from high temperature. Check for corrosion. Replace any damaged wires. Verify all mechanical connections are sufficiently tightened.

Enclosure

Access the enclosure and remove any accumulated dirt and debris. Vacuum enclosure whenever dust or dirt is present.

ISOLATION PROCEDURE

The following procedure should be followed to de-energize the PV-15208 for maintenance:

WARNING

The terminals of the PV input may be energized if the arrays are energized. In addition, allow 5 minutes for all capacitors within the enclosure to discharge after shutting down the PV-15208.

1. Turn the on/off switch to the off position.
2. Open the PV array disconnect switch (if present).
3. Open the AC disconnect (if present).
4. Open the isolation transformer circuit breaker.
5. Install lockout devices on the isolation transformer circuit breaker and PV disconnect switch.

TURN-ON PROCEDURE

Refer to Section 3 for a detailed first-time turn on procedure.

1. Remove any lockout devices from the isolation transformer circuit breaker and PV disconnect switch.
2. Close the isolation transformer circuit breaker.
3. Close the AC disconnect (if present).
4. Close the PV array disconnect switch (if present).
5. Turn the on/off switch to the on position.

After a 15 second initialization period and a 5 minute wake up period, the PV-15208 will automatically begin power tracking, given the PV voltage is greater than the PV start voltage setpoint.

SECTION 7
DRAWINGS AND PARTS LIST



150474 Rev F : Schematic, System, Grid Tied PV Inverter, PV-Series

150921 Rev B : Assembly, Main Enclosure, Control Components, 15 KVA, PV-15208
Table of Components

150920 Rev B : Envelope Drawing, Grid Tied Inverter, PV-15208

Underwriters Laboratories Listing Document, April 25, 2000

Underwriters Laboratories Listing Card, September 8, 2000

Accessories:

151258 - Combiner Box, 10 Pole, 600 VDC, Nema 3R

151260 - Combiner Box, 12 Pole, 600 VDC, Nema 3R

151177 - Transformer, 15 KVA, 3 Pole, 60 Hz, 208 Delta/WYE

NOTES:

[1.] AC TERMINAL BLOCKS USED ON PV10208 ONLY.

MAIN POWER DISTRIBUTION

THIS DRAWING IS THE CONFIDENTIAL AND PROPRIETARY INFORMATION OF TRACE TECHNOLOGIES WITHOUT TRACE TECHNOLOGIES' PRIOR WRITTEN CONSENT, IT SHALL NOT BE COPIED OR IN PART BE REPRODUCED. IT SHALL BE PROMPTLY RETURNED TO TRACE TECHNOLOGIES UPON REQUEST. © TRACE TECHNOLOGIES 1997

REVISION										
REV	ECO NUMBER	DATE	DRAWN	CHKD	ISSUED	MECH	ELEC	QUALITY	MFG	STRESS
A	ECO-134	8/4/99	CRF							
B	ECO-170	11/4/99	KGS							
C	ECO-176	1/17/00	GB							
D	ECO-263	5/22/00	CRF							
E	ECO-261	07/19/00	GB							
F	ECO-249	09/05/00	GB							

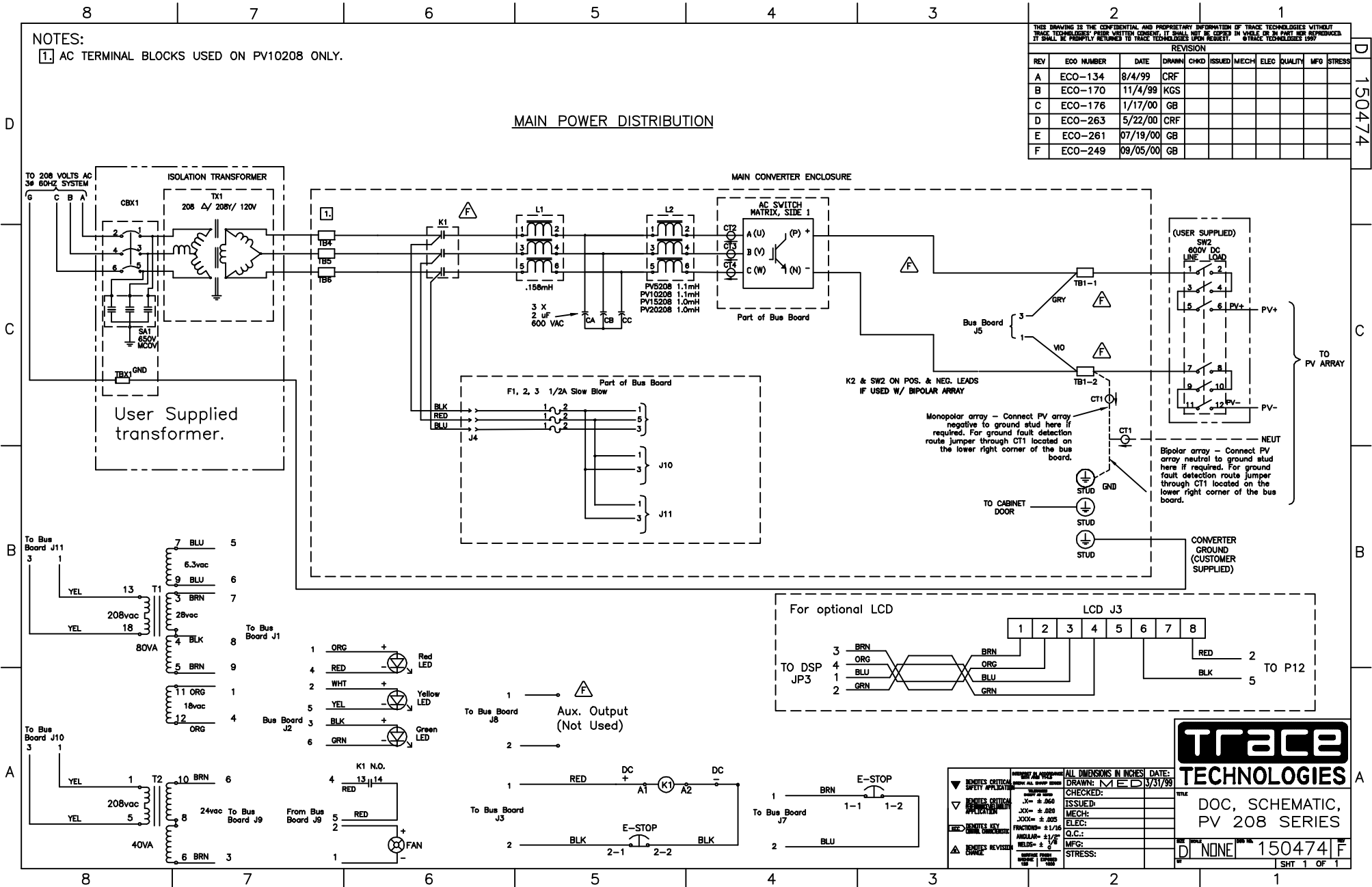

D 150474

C

B

A

TRACE TECHNOLOGIES

DOC, SCHEMATIC, PV 208 SERIES

DI NONE 150474 F

SHT 1 OF 1

<p>REVISIONS</p> <p>DATE: 3/31/99</p> <p>DRAWN: MED</p> <p>CHECKED:</p> <p>ISSUED:</p> <p>MECH:</p> <p>ELEC:</p> <p>Q.C.:</p> <p>MFG:</p> <p>STRESS:</p>	<p>ALL DIMENSIONS IN INCHES</p> <p>DATE: 3/31/99</p> <p>DRAWN: MED</p> <p>CHECKED:</p> <p>ISSUED:</p> <p>MECH:</p> <p>ELEC:</p> <p>Q.C.:</p> <p>MFG:</p> <p>STRESS:</p>
--	---

4

3

2

1

NOTES:

THIS DRAWING IS THE CONFIDENTIAL AND PROPRIETARY INFORMATION OF TRACE TECHNOLOGIES. WITHOUT TRACE TECHNOLOGIES' PRIOR WRITTEN CONSENT, IT SHALL NOT BE COPIED, IN WHOLE OR IN PART, NOR REPRODUCED. IT SHALL BE PROMPTLY RETURNED TO TRACE TECHNOLOGIES UPON REQUEST. TRACE TECHNOLOGIES CORP. 1997

REVISION						
REV	CHANGE	DATE	DRAWN	ENGR.	Q.LTY.	MFG.
A	ECO 202	01-13-00	GB			
B	ECO 337	11-14-00	GB			

A

150921

C

B

A

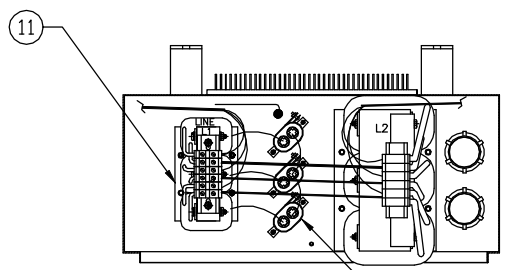

SECTION A-A

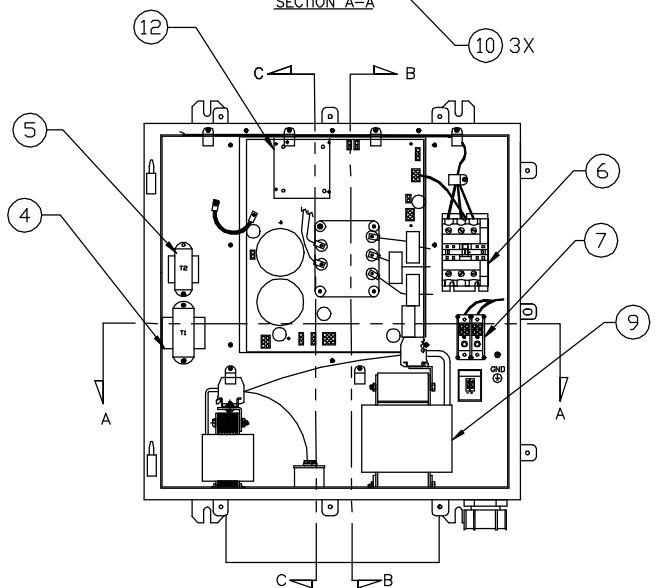

FRONT

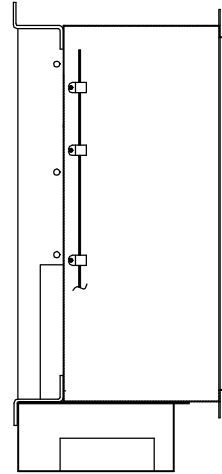

SECTION B-B

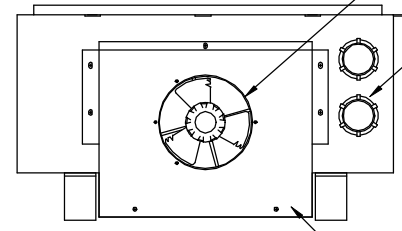

BOTTOM

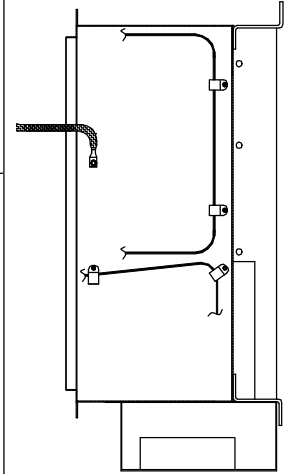

SECTION C-C

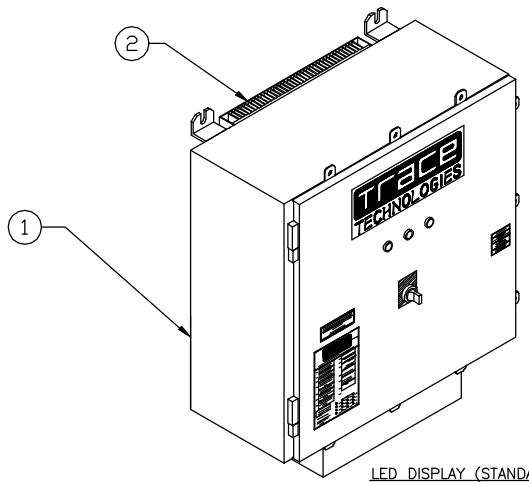

LED DISPLAY (STANDARD)

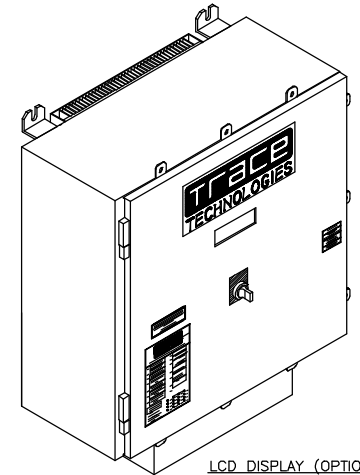

LCD DISPLAY (OPTIONAL)

▼ DENOTES CRITICAL SAFETY APPLICATION ▽ DENOTES CRITICAL PERFORMANCE/RELIABILITY APPLICATION ☐ DENOTES KEY CONTROL CHARACTERISTIC ▲ DENOTES REVISION CHANGE	INTERPRET IN ACCORDANCE WITH ANSI Y14.5 BREAK ALL SHARP EDGES TOLERANCES EXCEPT AS NOTED .X = ± .050 .XX = ± .020 .XXX = ± .005 FRACTIONS = ± 1/16 ANGULAR = ± 1/2° WELDS = ± 1/8 SURFACE FINISH MACHINE EXPOSED 125 EXPOSED 1000	ALL DIMENSIONS IN INCHES	DATE:
		DRAWN: G. BELTRAN	01-13-00
		ENGR:	
		Q.LTY:	
		MFG:	

Trace TECHNOLOGIES

TITLE: ENCLOSURE, CONTROL COMPONENTS, PV-15208

SIZE: A SCALE: NONE DWG NO.: 150921 REV: B

WT.: SHT 1 OF 2

4

3

2

1

**Trace Technologies PV-15208
Photovoltaic Inverter
Major Parts List**

Assembly Description: Main Enclosure, Control Components, PV-15208

Trace Technologies Assembly # 150921

Item #	Qty	Reference Designator	Trace Technologies Part #	Description
1	1		1-151139-01	Fab, Enclosure
2	1		1-150454-01	Heatsink, 13.312 X 15.25
3	1		1-151146-01	Fab, Fan Shroud
4	1	T1	1-150438-01	Transformer, 80VA
5	1	T2	1-150446-01	Transformer, 40VA
6	1	K1	1-150668-65	Contact, 3P, 24VDC Coil, 65A
7	1	TB1-2	1-150410-01	Block, Power Distribution, Mini 2P
8	1		1-150714-01	Fan, 24VDC, 6", 240CFM, 53.3dB
9	1	L2	1-150671-01	Inductor, 1.0mH, 65Arms
10	3	CA, CB, CC	1-150403-01	Capacitor, NP, 2UF, 600VAC, 6%
11	1	L1	1-150665-01	Reactor, Line, 158uH, 65Arms
12	1		1-150378-02	Assy, PCB, DSP
13	2		1-151199-06	Conduit, Liquid Tight Connector, Zinc

4

3

2

1

NOTES:

THIS DRAWING IS THE CONFIDENTIAL AND PROPRIETARY INFORMATION OF TRACE TECHNOLOGIES. WITHOUT TRACE TECHNOLOGIES' PRIOR WRITTEN CONSENT, IT SHALL NOT BE COPIED OR REPRODUCED IN ANY MANNER OR FOR ANY PURPOSE. IT SHALL BE PROMPTLY RETURNED TO TRACE TECHNOLOGIES UPON REQUEST. TRACE TECHNOLOGIES CORP. 1997

REVISION						
REV	CHANGE	DATE	DRAWN	ENGR.	Q.LTY.	MFG.
A	ECO 202	01-13-00	GB			
B	ECO 337	11-14-00	GB			

A

150920

C

B

A

D

C

B

A

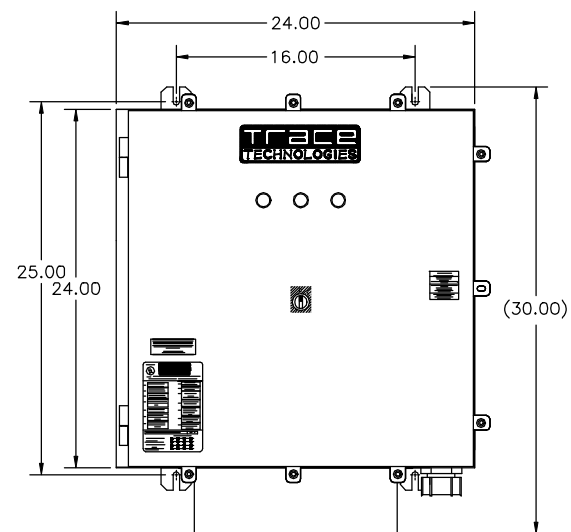
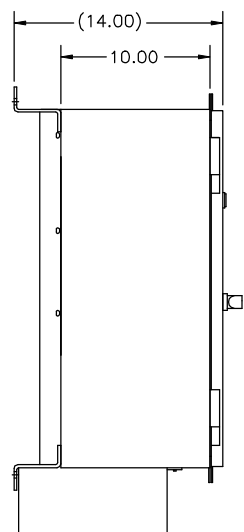
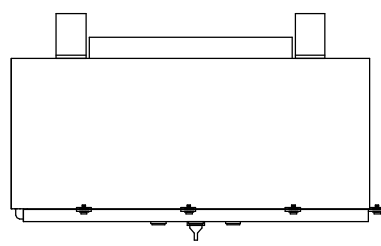

LED DISPLAY (STANDARD)

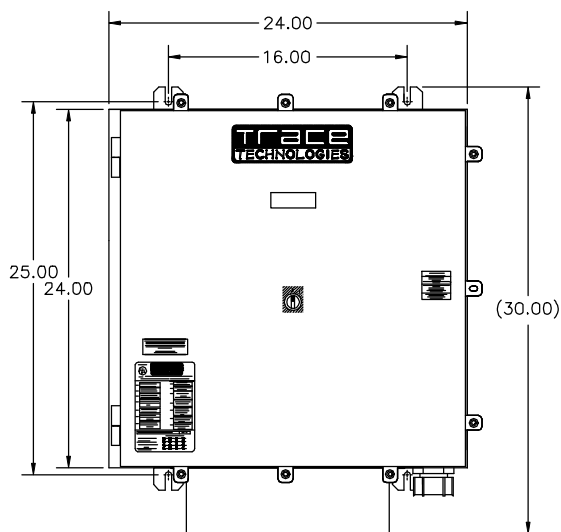

LCD DISPLAY (OPTIONAL)

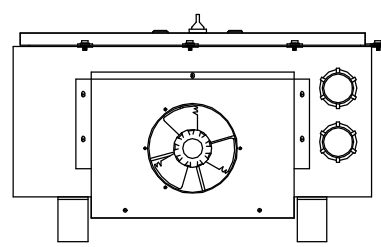
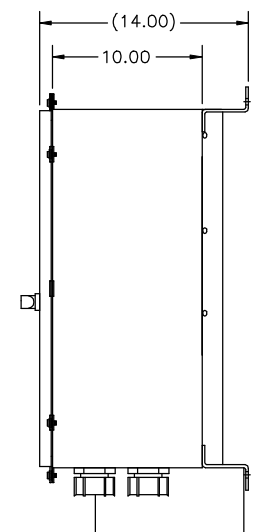

▼ DENOTES CRITICAL SAFETY APPLICATION ▽ DENOTES CRITICAL PERFORMANCE/RELIABILITY APPLICATION ■ DENOTES KEY CONTROL CHARACTERISTIC ▲ DENOTES REVISION CHANGE	INTERPRET IN ACCORDANCE WITH ANSI Y14.5 BREAK ALL SHARP EDGES TOLERANCES EXCEPT AS NOTED .X = ± .050 .XX = ± .020 .XXX = ± .005 FRACTIONS = ± 1/16 ANGULAR = ± 1/2° WELDS = ± 1/8 SURFACE FINISH MACHINE 125 EXPOSED 1000	ALL DIMENSIONS IN INCHES	DATE:
		DRAWN: G. BELTRAN	01-13-00
		ENGR:	
		Q.LTY:	
		MFG:	

Trace TECHNOLOGIES

TITLE: ENVELOPE, GRID TIED INVERTER, PV-15208

SIZE: A SCALE: NONE DWG NO.: 150920 REV: B

WT.: SHT 1 OF 1

4

3

2

1

QIKH.E199356



QIKH.E199356



[Page Bottom](#)

[LIS Home Page](#)

[Corporate Home Page](#)

Photovoltaic Static Inverters

TRACE TECHNOLOGIES CORP
PO BOX 5049
LIVERMORE, CA 94551 USA

February 14, 2001

E199356 (NBK)

Cutoff

Single phase wind turbine converters, Models BWT10240, Gridtec 10.

Three phase utility interactive photovoltaic inverters, Models BP-12U, BP-15U, BP-18U,
PV-5208, PV-10208, PV-15208, PV-20208.

LOOK FOR LISTING MARK ON PRODUCT

331210004

[Page Top](#)

[LIS Home Page](#)

[DMS \(NK\)](#)

[RTDLS](#)

[MEDLS](#)

[SCDLS](#)

[CADLS](#)

This page and all contents are Copyright © 2001 by Underwriters Laboratories Inc.®

The appearance of a company's name or product in this database does not in itself assure that products so identified have been manufactured under UL's Follow-Up Service. Only those products bearing the UL Mark should be considered to be Listed and covered under UL's Follow-Up Service. Always look for the Mark on the product.

This database is for INTERNAL USE ONLY.

QIKH.GuideInfo Photovoltaic Static Inverters

[Page Bottom](#)[Notice of Disclaimer](#)[Previous Page](#)

[Photovoltaic Power Systems Equipment] Photovoltaic Static Inverters

Guide Information

This category covers permanently connected static inverters which change dc electric power from photovoltaic arrays to 50/60 Hz ac electric power. They are intended for use in parallel (interactive) with a single-phase electric utility supply or as a stand-alone system.

The static inverters covered by this category are rated up to 600 V dc, input; 10 kW, 120/240 v or less, single-phase output and are intended to be installed in accordance with the National Electrical Code, including Article 690. Static inverters are either provided with dc isolation between the input and output circuits or are marked indicating that the installer is to provide an isolation transformer in the output circuit of the inverters.

The proposed standard "Static Inverters and Charge Controllers for use in Photovoltaic Power Systems" , UL 1741, is used to investigate products in this category.

The Listing Mark of Underwriters Laboratories Inc. on the product is the only method provided by UL to identify products manufactured under its Listing and Follow-Up Service. The Listing Mark for these products includes the name and/or symbol of Underwriters Laboratories Inc. together with the word "LISTED" , a control number and one of the following product names: "Power Conditioning Unit" , "Static Inverter" , "Utility Interactive Inverter" or other appropriate product name.

[Page Top](#)[Notice of Disclaimer](#)[Previous Page](#)

This page and all contents are Copyright © 2001 by Underwriters Laboratories Inc.®

The appearance of a company's name or product in this database does not in itself assure that products so identified have been manufactured under UL's Follow-Up Service. Only those products bearing the UL Mark should be considered to be Listed and covered under UL's Follow-Up Service. Always look for the Mark on the product.

4

3

2

1

NOTES:

- 1. ENCLOSURE AND DOOR ARE FABRICATED FROM CODE GAUGE GALVANIAL STEEL. 16 GAUGE (.0598)
- 2. STANDARDS: UL 50 LISTED, CSA C22.2 NO. 40 CERTIFIED, TYPE 3R CONFORMS TO NEMA STANDARD FOR TYPE 3R, IEC 529, IP32
- 3. RATINGS: MAX. VOLTAGE RATING - 600 VDC, MAX FUSE SIZE - 20 AMPS
- 4. WIRE RANGE: SOURCE #8-14 AWG, OUTPUT #2-6 AWG.

THIS DRAWING IS THE CONFIDENTIAL AND PROPRIETARY INFORMATION OF TRACE TECHNOLOGIES. WITHOUT TRACE TECHNOLOGIES' PRIOR WRITTEN CONSENT, IT SHALL NOT BE COPIED, IN WHOLE OR IN PART, NOR REPRODUCED. IT SHALL BE PROMPTLY RETURNED TO TRACE TECHNOLOGIES UPON REQUEST. TRACE TECHNOLOGIES CORP. 1997

REVISION						
REV	CHANGE	DATE	DRAWN	ENGR.	Q.LTY.	MFG.
A	ECO-314	09-11-00	GB			

A

151258

C

B

A

D

C

B

A

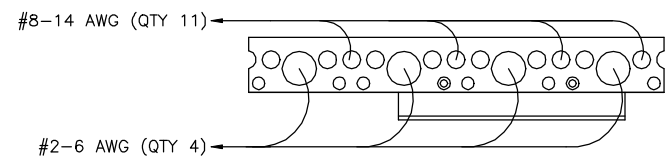
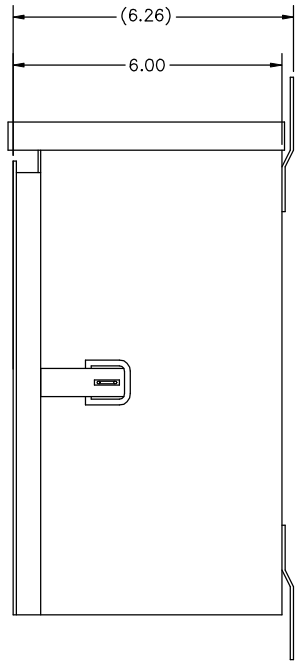
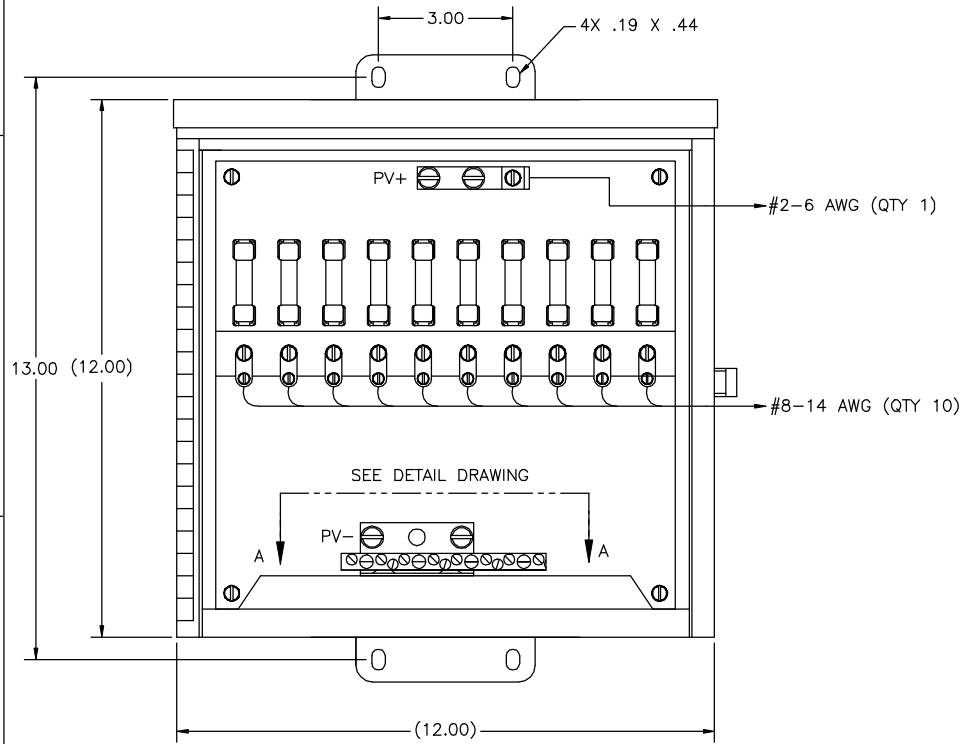

DETAIL A-A

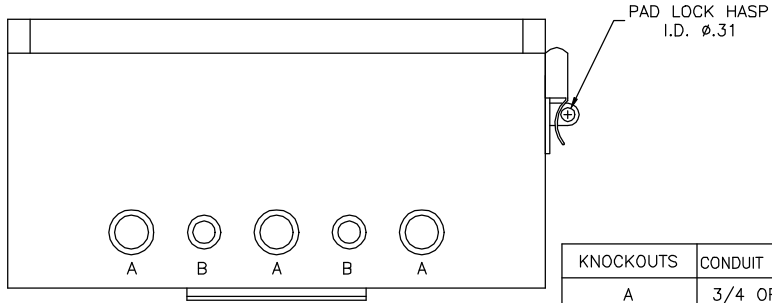

KNOCKOUTS	CONDUIT SIZE
A	3/4 OR 1
B	1/2 OR 3/4

▼ DENOTES CRITICAL SAFETY APPLICATION ▽ DENOTES CRITICAL PERFORMANCE/RELIABILITY APPLICATION ■ DENOTES KEY CONTROL CHARACTERISTIC ▲ DENOTES REVISION CHANGE	INTERPRET IN ACCORDANCE WITH ANSI Y14.5 BREAK ALL SHARP EDGES TOLERANCES EXCEPT AS NOTED .X = ± .050 .XX = ± .020 .XXX = ± .005 FRACTIONS = ± 1/16 ANGULAR = ± 1/2° WELDS = ± 1/8 SURFACE FINISH MACHINE 125 EXPOSED 1000	ALL DIMENSIONS IN INCHES	DATE:
		DRAWN: G. BELTRAN	09-11-00
		ENGR:	
		Q.LTY:	
		MFG:	

1-151258-01	CB-10H20-3R
PART NUMBER	
Trace TECHNOLOGIES	
TITLE COMBINER BOX, 10 POLE, 600 VDC, NEMA 3R	
SIZE A	SCALE NONE
DWG NO. 151258	REV A
SHT 1 OF 1	

4

3

2

1

4

3

2

1

NOTES:

- 1. ENCLOSURE AND DOOR ARE FABRICATED FROM CODE GAUGE GALVANIAL STEEL. 16 GAUGE (.0598)
- 2. STANDARDS: UL 50 LISTED, CSA C22.2 NO. 40 CERTIFIED, TYPE 3R CONFORMS TO NEMA STANDARD FOR TYPE 3R, IEC 529, IP32
- 3. RATINGS: MAX. VOLTAGE RATING - 600 VDC, MAX FUSE SIZE - 20 AMPS
- 4. WIRE RANGE: SOURCE #6-14 AWG, OUTPUT TWO 1/0-14 AWG.

THIS DRAWING IS THE CONFIDENTIAL AND PROPRIETARY INFORMATION OF TRACE TECHNOLOGIES. WITHOUT TRACE TECHNOLOGIES' PRIOR WRITTEN CONSENT, IT SHALL NOT BE COPIED OR IN ANY MANNER REPRODUCED. IT SHALL BE PROMPTLY RETURNED TO TRACE TECHNOLOGIES UPON REQUEST. TRACE TECHNOLOGIES CORP. 1997

REVISION					
REV	CHANGE	DATE	DRAWN	ENGR.	MFG.
A	ECO-314	09-11-00	GB		

A

151260

C

B

A

D

C

B

A

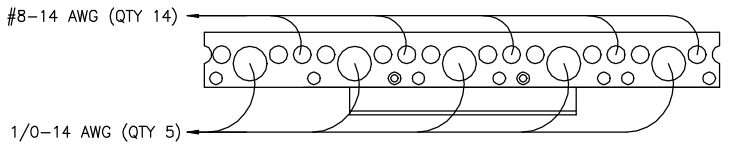
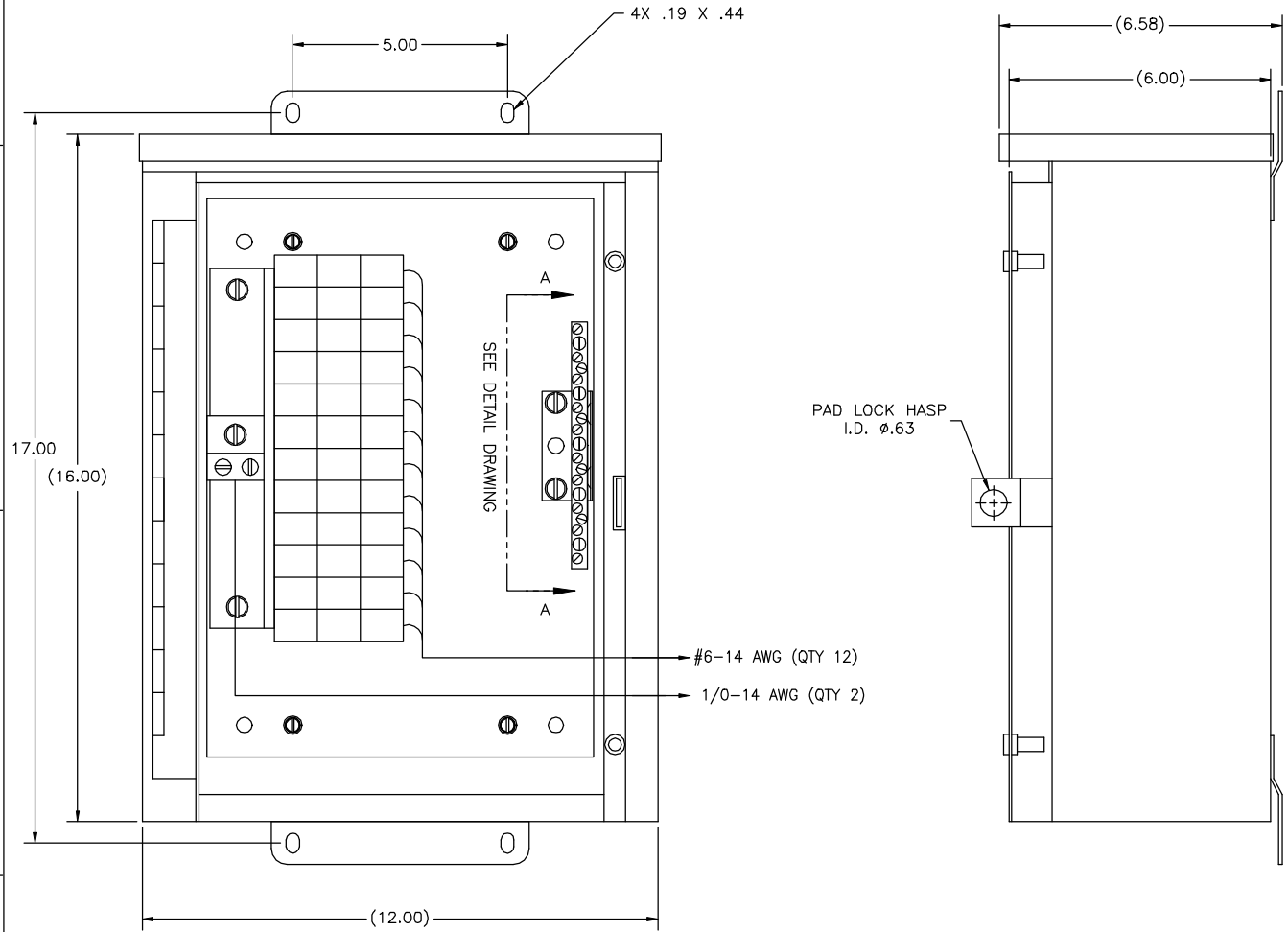

DETAIL A-A

▼ DENOTES CRITICAL SAFETY APPLICATION	INTERPRET IN ACCORDANCE WITH ANSI Y14.5 BREAK ALL SHARP EDGES	ALL DIMENSIONS IN INCHES		DATE:
		DRAWN: G. BELTRAN		09-11-00
▽ DENOTES CRITICAL PERFORMANCE/RELIABILITY APPLICATION	TOLERANCES EXCEPT AS NOTED .X = ± .060 .XX = ± .020 .XXX = ± .005 FRACTIONS = ± 1/16 ANGULAR = ± 1/2° WELDS = ± 1/8"	ENGR:		
		QTY:		
☐ DENOTES KEY CONTROL CHARACTERISTIC	SURFACE FINISH MACHINE 125 EXPOSED 1000	MFG:		
△ DENOTES REVISION CHANGE				

1-151260-01	CB-12H20-3R
PART NUMBER	
Trace TECHNOLOGIES	
TITLE COMBINER BOX, 12 POLE, 600 VDC, NEMA 3R	
SIZE A	SCALE NONE
WT.	DWG NO. 151260
REV A	
SHT 1 OF 1	

4

3

2

1



Trace Technologies Corporation
3547C South Higuera Street
San Luis Obispo, CA, USA 93401

Installation Instructions for Photovoltaic Combiner Box

Unit should be mounted in the vertical position using integral mounting tabs with appropriate hardware (not included).

MODEL NUMBER	MAX DC VOLTAGE	MAX FUSE SIZE	MAX SOURCE Isc	MAX RATED OUTPUT I
CB-10H20-3R	600	20A	12.8A	101A
CB-10HD8-3R	600	8A	5A	64A
CB-12H20-3R	600	20A	12.8A	192A
CB-12H20-4	600	20A	12.8A	192A

Wiring methods shall be in accordance with National Electrical Code, Article 310 and 690, ANSI/NFPA 70. Copper conductors only, 75°C.

Wiring requirements are as follows:

MODEL NUMBER	SOURCE WIRE RANGE	OUTPUT WIRE RANGE
CB-10H20-3R	#14 to #8	#6 to #2
CB-10HD8-3R	#14 to #8	#6 to #2
CB-12H20-3R	#14 to #6	(2) #14 to (2) 1/0
CB-12H20-4	#14 to #6	(2) #14 to (2) 1/0

For Model numbers CB-10H20-3R and CB-10HD8-3R reference attached drawing for appropriate output wire routing requirements.

Chassis ground may be accomplished using supplied ground screw in base of unit.

Recommended tightening torque (pound-inch):

#18 - #10	#8	#6 - #3	#2	#1/0
20	25	35	40	50

FIRE HAZARD-When wiring is complete, check all terminal screws for proper torque.

A SUITABLE DC RATED SYSTEM DISCONNECT SHALL BE USED IN CONJUNCTION WITH THE INSTALLATION OF THIS EQUIPMENT.

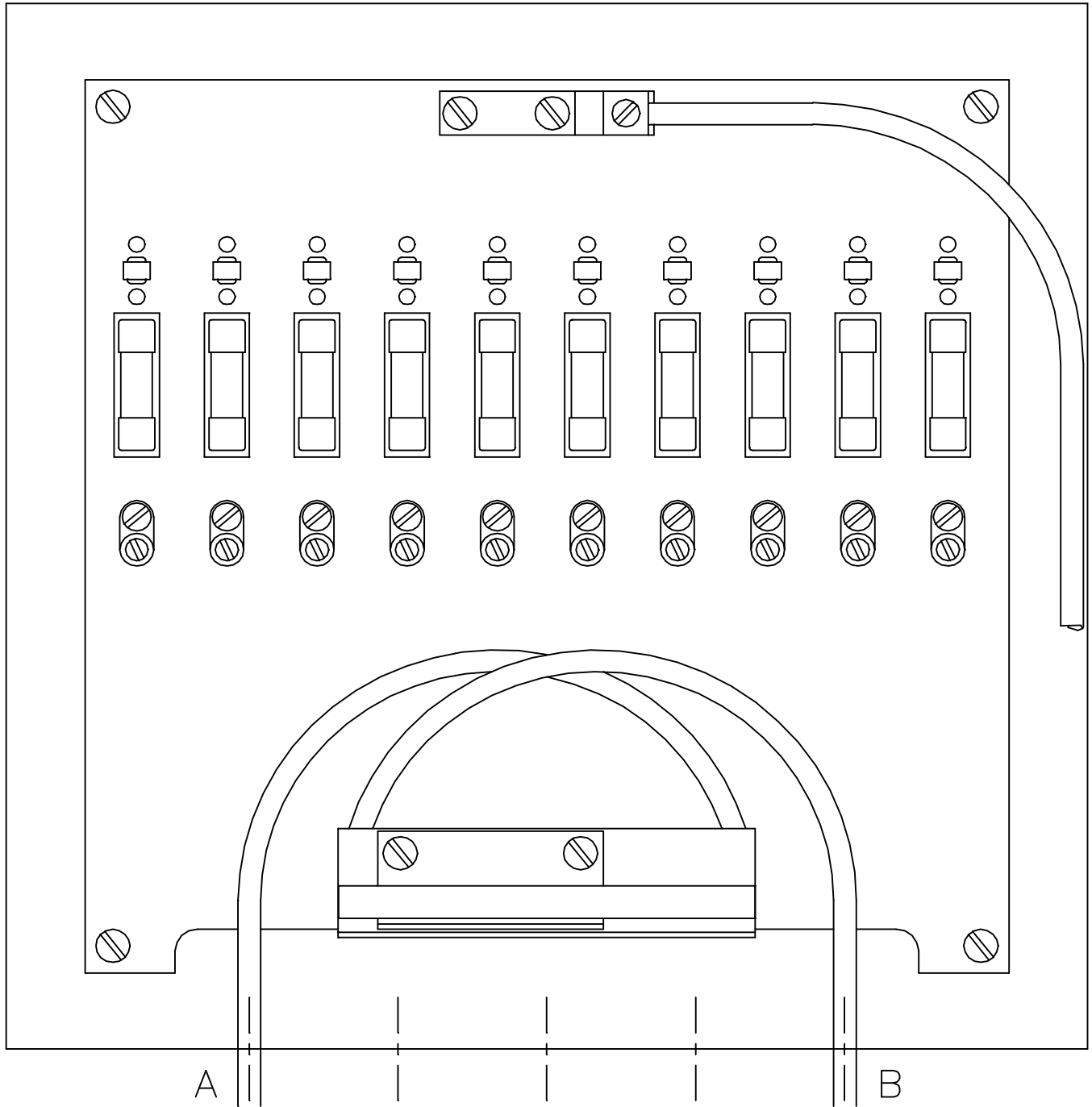

LARGE OUTPUT WIRES ARE TO ENTER THE COMBINER BOX FROM EITHER OF THE OUTERMOST KNOCKOUTS (A OR B) AND LOOP TO THE FARTHEST LARGE GAUGE TERMINAL ON THE -PV BUS BAR TO INSURE MINIMUM WIRE BENDING REQUIREMENTS PER UL1741.

NOTES:

1. ALL UNITS ARE UL LISTED AND ARE DESIGNED IN ACCORDANCE WITH APPLICABLE NEMA, ANSI, AND IEEE STANDARDS.
2. TRANSFORMERS ARE DRY-TYPE, CLASS AA, VENTILATED NEMA 2 ENCLOSURE.
3. WITH INSTALLATION OF OPTIONAL WEATHER SHIELDS, TRANSFORMER BECOMES NEMA 3R FOR OUTDOOR USE.
4. TRANSFORMERS ARE FLOOR MOUNTED.
5. TRANSFORMERS HAVE 220°C CLASS INSULATION SYSTEM WITH 80°C AVERAGE WINDING TEMPERATURE RISE OVER 40°C MAXIMUM AMBIENT.
6. PAINT COLOR IS ANSI #61 (GREY).
7. ALUMINUM WINDINGS WITH ALUMINUM TERMINALS
8. UNITS HAVE ELECTROSTATIC SHIELD GROUNDED TO TRANSFORMER CASE AT FACTORY.

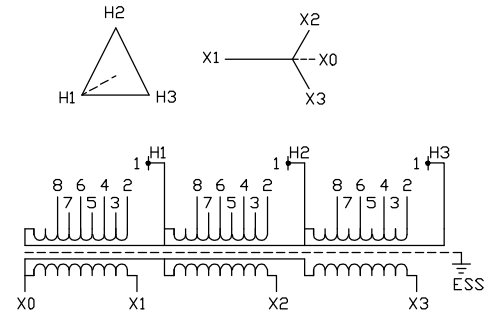
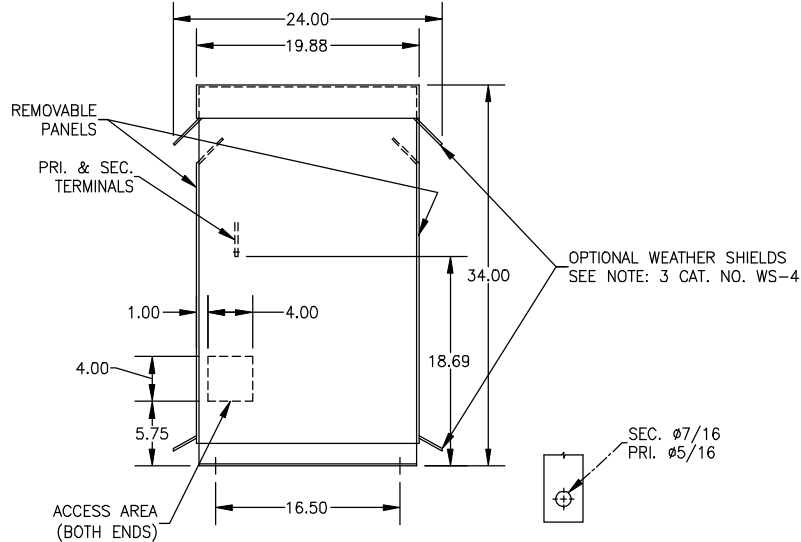
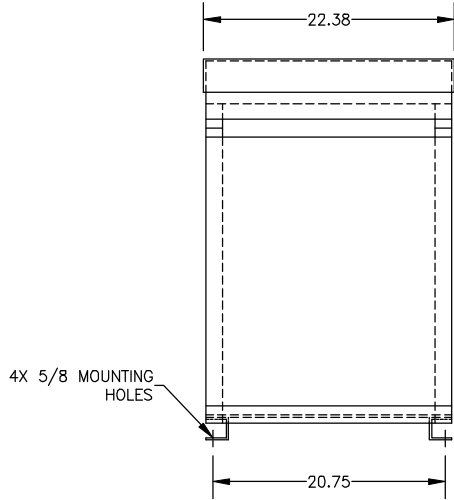

TYPICAL WIRING DIAGRAM #1

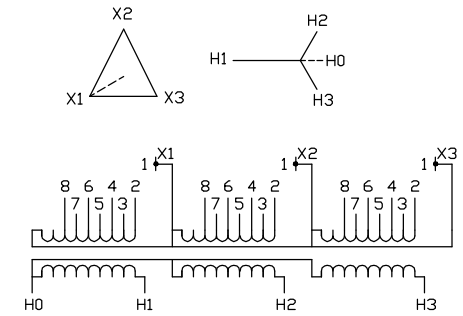

TYPICAL WIRING DIAGRAM #2

MFG'S PART	VOLTAGE		KVA	TEMP. RISE	TAPS	WEIGHT	WIRING DIAGRAM
	PRIMARY	SECONDARY					
T202H15BS	208	208Y/120	15	80°C	+2, -2, X 2-1/2%	285 LBS.	#1
T204H15B	208	480Y/277	15	80°C	+2, -2, X 2-1/2%	285 LBS.	#2



SIZE A	SCALE NONE	DWG NO. 151177	REV B
WT.		SHT 2 OF 3	

A 151177

C

B

A

NOTES:

1. UL LISTED.
2. NEMA 2 VENTILATED ENCLOSURE.
3. ALUMINUM WOUND.
4. TRANSFORMERS ARE FLOOR MOUNTED.
5. TRANSFORMERS HAVE 220°C CLASS INSULATION SYSTEM WITH 80°C AVERAGE WINDING TEMPERATURE RISE OVER 40°C MAXIMUM AMBIENT.
6. USE WEATHERSHIELD CAT WS363 FOR NEMA 3R.

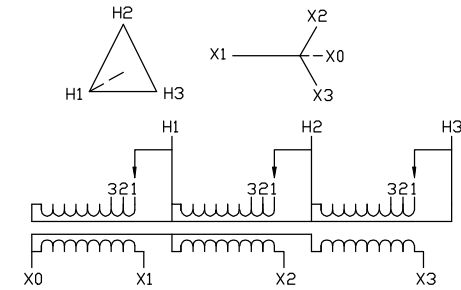
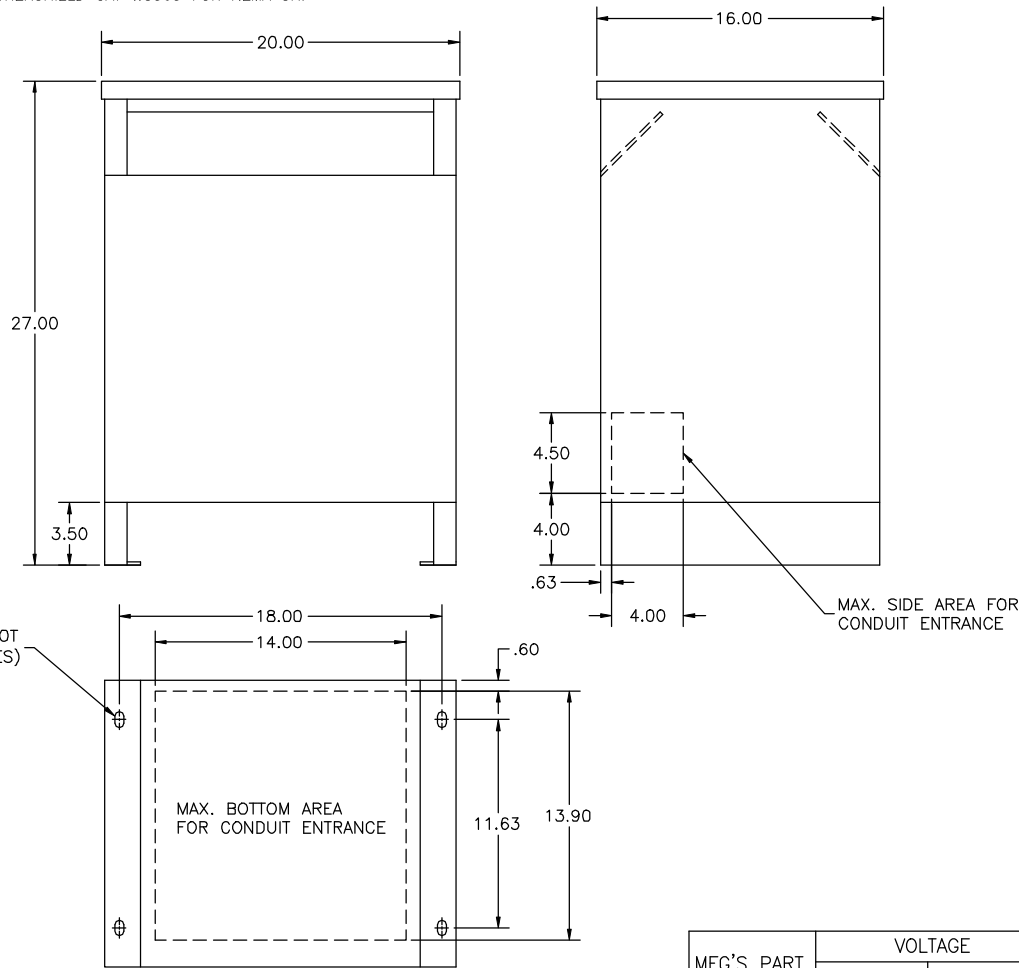

TYPICAL WIRING DIAGRAM #1

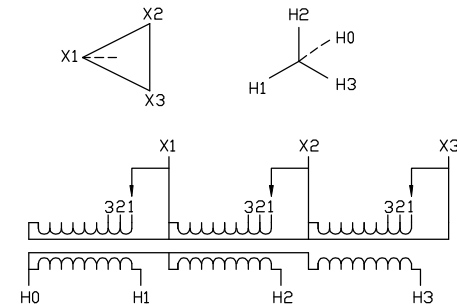

TYPICAL WIRING DIAGRAM #2

IN EACH PHASE CONNECT TO TAPS	
PRIMARY VOLTS	2-5% FCBN
208	1
198	2
188	3

MFG'S PART	VOLTAGE		KVA	TEMP. RISE	SOUND LEVEL	AMBIENT	WEIGHT	WIRING DIAGRAM
	PRIMARY	SECONDARY						
15T85HB	208	208Y/120	15	80°C	45 dB	40°C	250 LBS.	#1
15T64HB	208	480Y/277	15	80°C	45 dB	40°C	250 LBS.	#2



SIZE A	SCALE NONE	DWG NO. 151177	REV B
WT.		SHT 3 OF 3	

A 151177

C

B

A